

TW SERIES

25-302SH

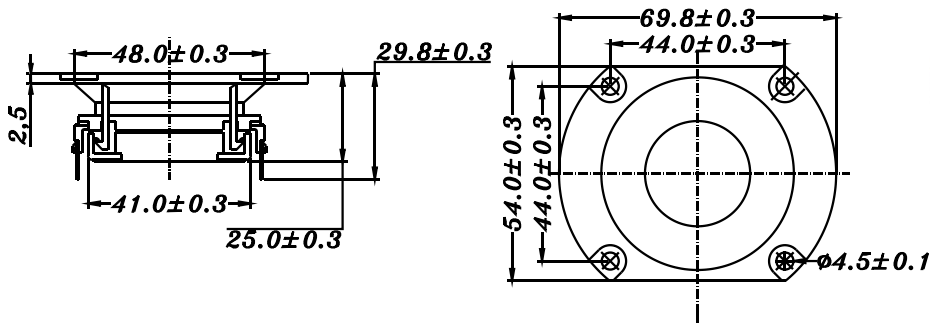

- SOFT FABRIC DOME DIAPHRAGM COATING WITH HIGH LOSS MATERIAL
- FERROFLUID COOLED
- DAMP WOOL IN CAVITY OF POLE PIECE
- ABS FRONT PANEL
- NEODYMIUM DESIGN
- CCAW VOICE COIL

1" FABRIC DOME/ NEODYMIUM

DIAPHRAGM MTL	Fabric
SURROUND MTL	N/A
NOMINAL IMPEDANCE	8 Ω
DCR IMPEDANCE	6 Ω
SENSITIVITY 1W/1m	91 dB
FREQUENCY RESPONSE	1400k -20K Hz
FREE AIR RESONANCE	1400 Hz
VOICE COIL DIAMETER	25.4 mm
AIR GAP HEIGHT	2 mm
RATED POWER INPUT	8 W
MAXIMUM POWER INPUT	80 W
FORCE FACTOR, BL	N/A
MAGNET WEIGHT	Neodymium
MOVING MASS	N/A
FERROFLUID ENHANCED	Yes
SUSPENSION COMPLIANCE	N/A
EFFECTIVE PISTON AREA	N/A
Levc	N/A
Zo	N/A
X-max	N/A
Vas	N/A
Qts	N/A
Qms	N/A
Qes	N/A

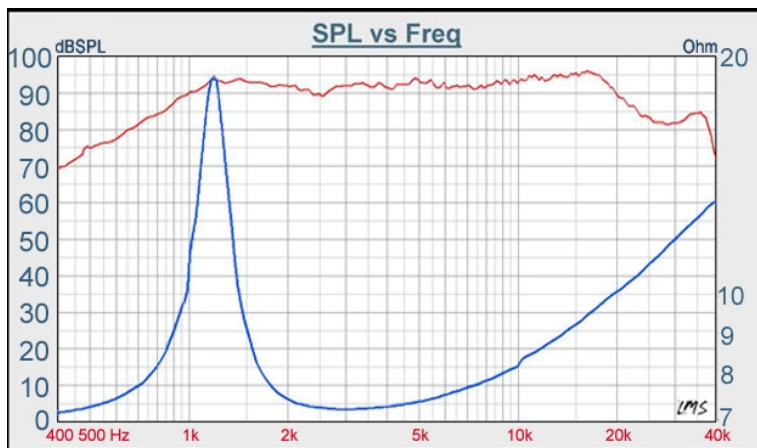

TB SPEAKERS

VOICE: 886.2.26570282 FAX: 886.2.26580166
E-MAIL: info@tb-speaker.com